

# Application Note - Using an Arbitrary Waveform Generator for Threat Generation

Authors: Mark Elo, Giga-tronics & Christopher Loberg, Tektronix  
Published: August 1, 2015  
Revision: A





## Introduction

An arbitrary waveform generator (AWG) is a piece of electronic test equipment used to generate electrical signal waveforms. These waveforms can be generated as either continuous/repetitive or single-shot.

For the threat generation application it is assumed that waveforms will be single shot and will represent different types of radar PRI's associated with different threats. Each Radar waveform can also have a number of modes such as search and track.

## AWG Architecture

The following block diagram is typical of a Commercial-off-the-Shelf (COTS) AWG solution such as the Tektronix AWG7000 series or AWG70000 series arbitrary waveform generators.

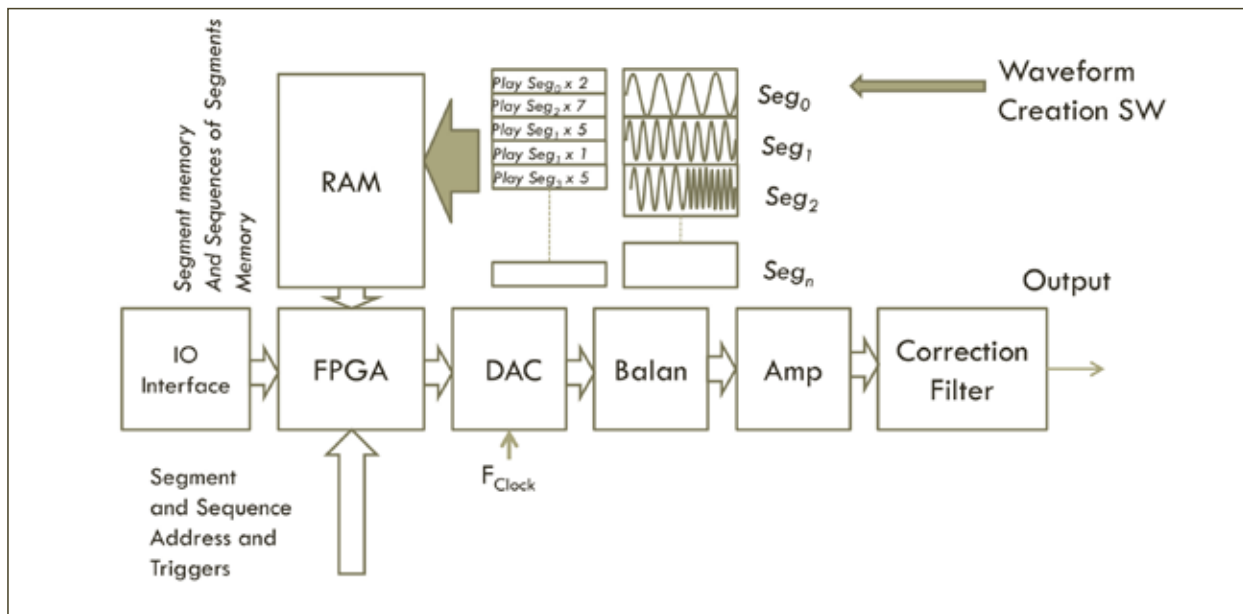

The Tektronix RFXpress® software is used to generate various RF waveforms that are loaded into the instrument through an I/O interface such as LAN, or PCIe. In some cases such as the Tektronix AWG70000 the waveform generation software is native to the instrument, in other cases a separate PC software program is used such as MATLAB®.

**Memory:** Waveforms can be stored in Memory segments and groups of segments can be played out as sequences. For example, a scan pattern could be stored in segment memory zero, and a sequence zero could play segment zero 2 times, then stop.

There are two types of memory employed in COTS AWG's: Static and Dynamic. A static memory can be accessed much faster than a dynamic RAM; however the overall storage capacity of static RAM is small compared to that of dynamic RAM. Typically a high performance arbitrary waveform generator has dynamic RAM.

**Dynamic Memory Access:** Segments and sequences can be played out on demand by using dynamic or pattern jump interfaces that address a particular waveform then initiate play out utilizing a trigger. Tektronix AWG's have an 8 bit parallel interface allowing for 256 segment addresses.



**Digital to Analog Converter:** The D to A converter varies in sample rates depending on the overall instruments frequency range. The sampling rate, and oversample added will affect the Spurious Free Dynamic Range (SFDR) of the instrument.

**Amplifier:** The choice of amplifier in the output stage will determine any harmonics. When using an up-converter in conjunction with an AWG, the harmonics will often be out of the IF band. Or if the AWG is generating signals direct to microwave the harmonics are often out of the band of the system under test. In some bases though, especially when generating wideband Chirp signals the harmonics will be in band.

**Output Filtering:** Some waveform generators typically don't have a robust output filtering scheme; therefore images, spurs and other spectral anomalies may occur. The example below shows a 6 GHz sweep on a spectrum analyzer. The intended wide bandwidth chirp is at 1.2 GHz, the other displayed signals are all anomalies of the signal creation method.

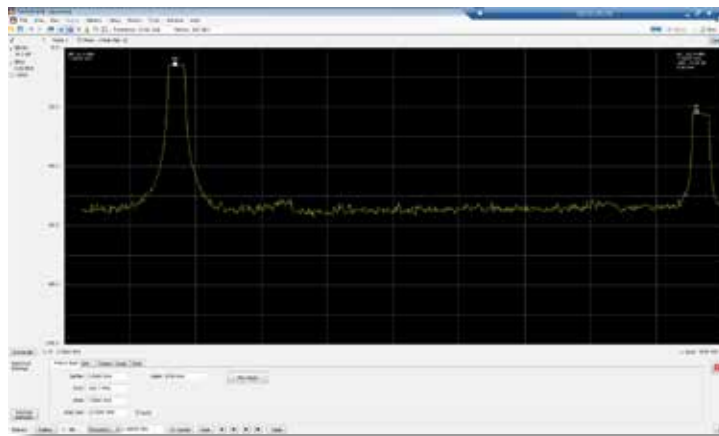

An AWG like the Tektronix AWG70000 series also has an option for a built in amplifier and filter system for direct microwave signal generation. An example of the OPT AC interface is shown below.

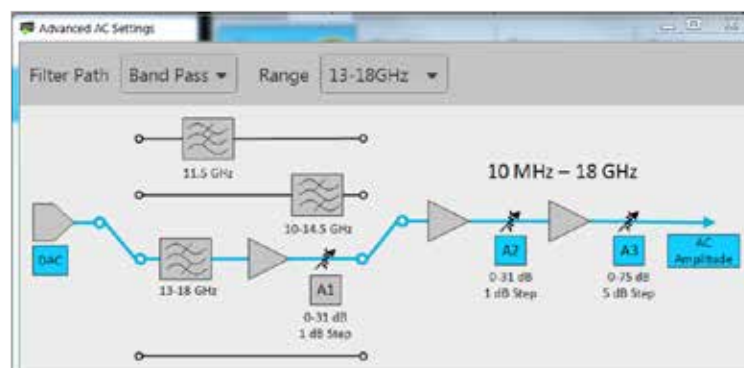





## Threat Creation

The following needs to be taken into account when generating threats:

1. The ability to add attenuation to emulate antenna patterns, azimuth and elevation characteristics.
2. Multiple output ports to simulate direction.
3. The ability to add Doppler pulse to pulse.
4. Deterministic playback of waveforms that emulate a radar frame or mode.
5. The ability to change waveforms quickly.
6. Digitally modulated real time FSK waveforms for data links.
7. SFDR > 60 dBc.

## Direct to Microwave

High sample rate AWG's like the Tektronix AWG70000 Series can generate directly to RF or microwave frequencies. They have waveform creation software that allows you to generate sets of PRI's that can contain a scan pattern from a fixed location. More memory can be used to create infinite sets of waveforms that contain all movement changes in amplitude, phase and frequency. However this quickly becomes overwhelming data set and requires the ability of addressing thousands of waveforms.

COTS AWG instrumentation also has limited provision for dynamic amplitude changes to the waveform.

A scheme outlined below would have to be used to with a direct microwave generation system. Scheduling hardware would need to be contracted to a third party, along with a finely tuned DDS for digital modulation, a Doppler pulse modulator and a dynamic attenuator. (If dynamic waveform play-out is not required, the whole scenario can be modeled in a single AWG file and no changes to the play out order would be required and only the AWG would be required).

When a modulated pulse is not required the scheduling HW can set the AWG to play out a sine wave of the desired frequency and switch the modulator on and off for the desired pulse duration. The DDS can be set to add Doppler pulse and the attenuator would be used to emulate skin return, azimuth and elevation along with the appropriate antenna pattern.

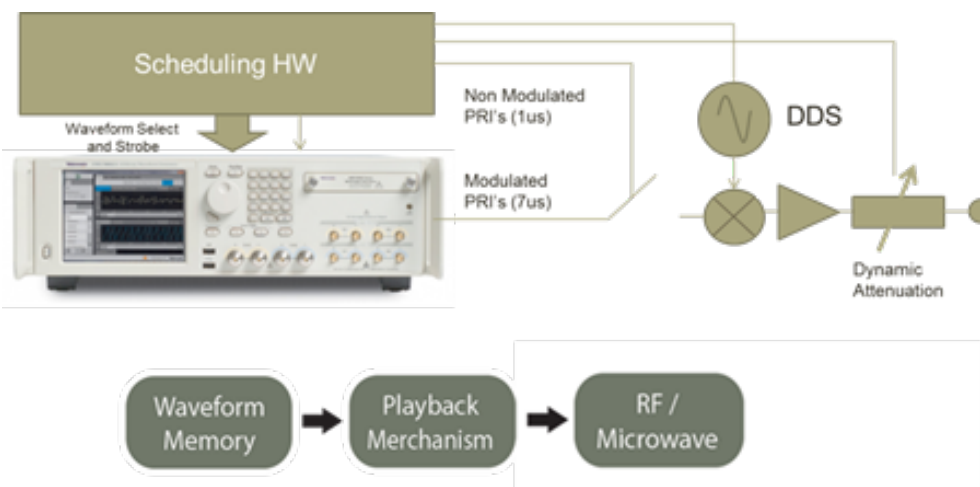



All changes in this set up will be in 6  $\mu$ s increments as that is the latency from trigger to play out. This time can vary depending on sample rate, so a fixed sample rate would be recommended to keep the waveform's absolute timing.

**Signal Format**

IQ  IF/RF

Pulse name:

Sampling Rate   Automatic

Oversampling

Certain combinations of sample rates, waveform frequency and length will result in sub-optimal SFDR. If the sample rate changes, the time to waveform play out will change as well, so when creating waveforms it is important to keep this sample rate fixed. However if that sample rate causes a worse case SFDR as shown in the table below, then a more optimal sample rate must be chosen and the strobe timing adjusted to keep the system timing accurate.

The table below shows the worst case SFDR of an AWG playing out direct to microwave. The SFDR in the C-Band and the X-Band are 45 dBc and 50 dBc respectively. These values are marginal; ideally we would like to stimulate the SUT with a SFDR range of over 60 dBc.

	In Band SFDR Performance		Adjacent Band SFDR Performance	
	Measured Across	Specification (typical)	Measured Across	Specification (typical)
100 MHz	DC to 1 GHz	-80 dBc	DC to 10 GHz	-72 dBc
DC to 500 MHz	DC to 500 MHz	-70 dBc	DC to 1.5 GHz	-66 dBc
DC to 1 GHz	DC to 1 GHz	-63 dBc	DC to 3 GHz	-63 dBc
DC to 2 GHz	DC to 2 GHz	-62 dBc	DC to 6 GHz	-60 dBc
DC to 3 GHz	DC to 3 GHz	-60 dBc	DC to 6 GHz	-52 dBc
DC to 5 GHz	DC to 5 GHz	-52 dBc	DC to 6 GHz	-52 dBc
5 GHz to 6 GHz	5 GHz to 6 GHz	-52 dBc	3 GHz to 9 GHz	-40 dBc
6 GHz to 7 GHz	6 GHz to 7 GHz	-42 dBc	4 GHz to 10 GHz	-42 dBc
7 GHz to 8 GHz	7 GHz to 8 GHz	-60 dBc	6 GHz to 12.5 GHz	-52 dBc
8 GHz to 10 GHz	8 GHz to 10 GHz	-50 dBc	6 GHz to 12.5 GHz	-52 dBc
10 GHz to 12 GHz	10 GHz to 12 GHz	-53 dBc	6 GHz to 12.5 GHz	-50 dBc
12 GHz to 13 GHz	12 GHz to 13 GHz	-22 dBc	10 GHz to 15 GHz	-22 dBc
13 GHz to 14 GHz	13 GHz to 14 GHz	-54 dBc	11 GHz to 16 GHz	-20 dBc
14 GHz to 16 GHz	14 GHz to 16 GHz	-46 dBc	13 GHz to 18 GHz	-38 dBc
16 GHz to 18.5 GHz	16 GHz to 18.5 GHz	-42 dBc	14 GHz to 20 GHz	-30 dBc
18.5 GHz to 20 GHz	18.5 GHz to 20 GHz	-28 dBc	16 GHz to 20 GHz	-24 dBc



## Direct to IF

Another approach is to use a COTS up-converter such as the Giga-tronics GT-ASGM18A. This allows the AWG to generate to an IF at a lower frequency, ensuring the SFDR will be in excess of 60 dBc. Also the IF input is banded within +/- 500 MHz so if an appropriate sample rate is chosen, SFDR can be optimized to be greater than 80 dBc.

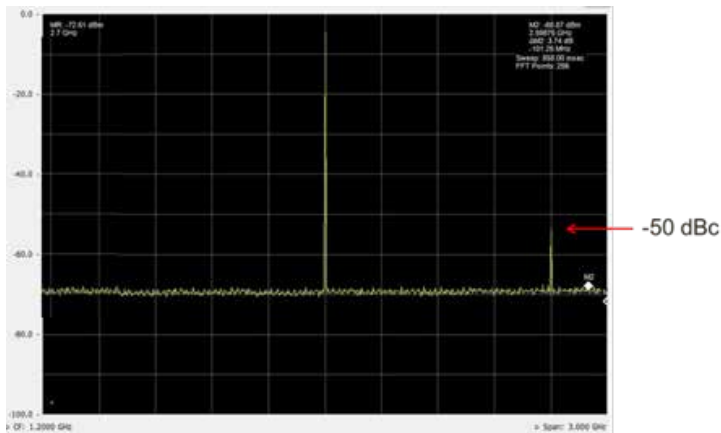

The Tektronix AWG70000 Series centered at 1.2 GHz IF.

Consider the GT-ASGM18A block diagram shown below. The Tektronix AWG70000 can be used to generate an IF signal at 1.2 GHz or 3.6 GHz. If modulation on pulse is not required the GT-ASGM18A can either be fed by a CW from the waveform generator or a higher fidelity 1200 MHz CW signal can be switched in. The pulse modulator can be directly controlled and frequency and amplitude switching can be achieved in less than a microsecond.

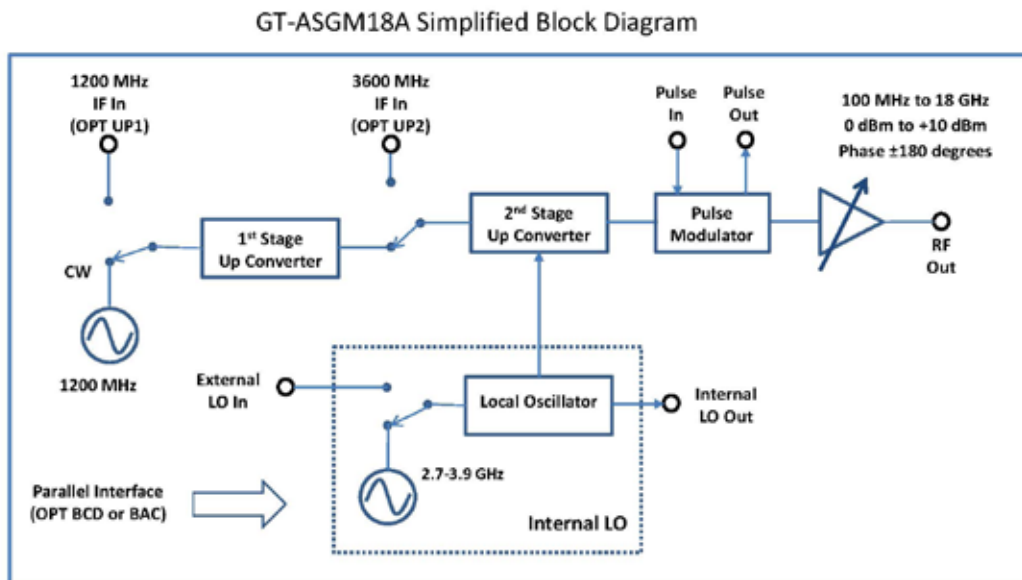



The following plot shows two PRI's both centered at 1.2 GHz. The first group of pulses is a high duty cycle modulated and hop within the IF of the up-converter, the second group is a low duty cycle modulated PRI.

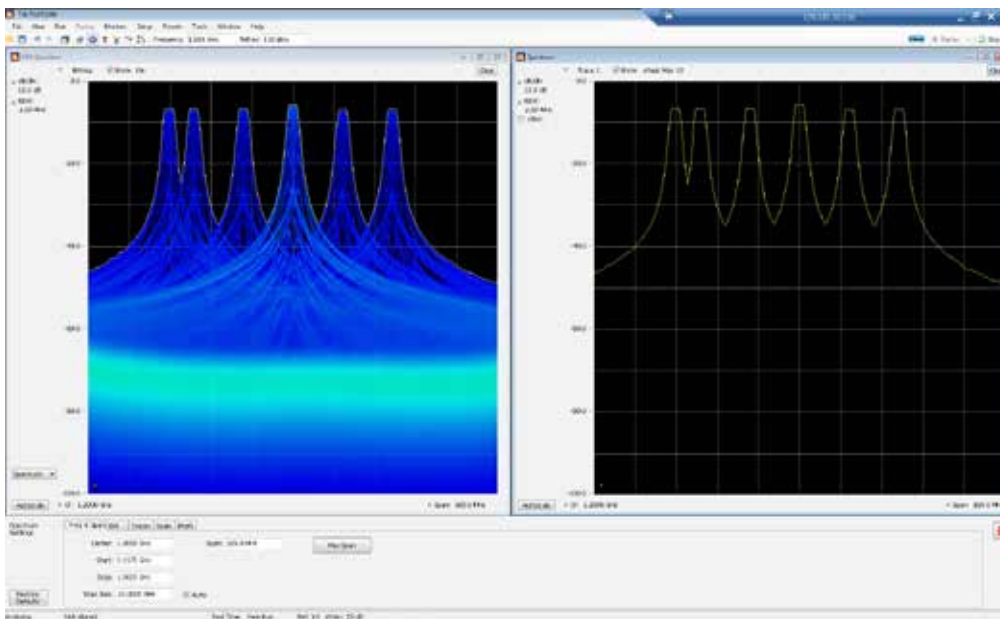
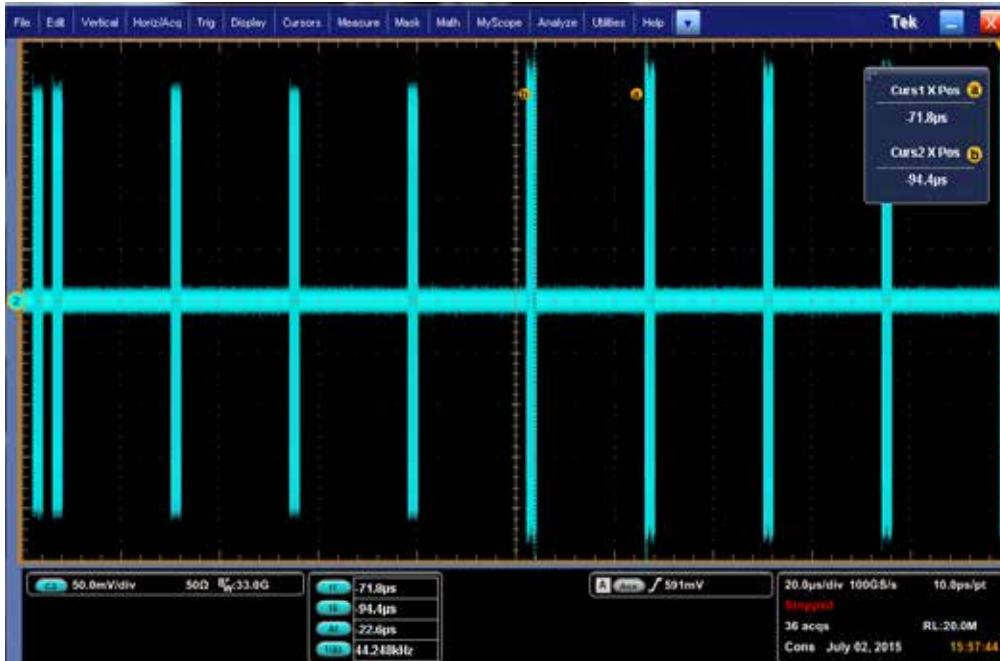



An optional 90dB attenuator can be added to the GT-ASGM18A allowing amplitude changes in 0.25 dB increments.

The GT-ASGM18A also has a COTS AWG compatible control, eliminating the need for a waveform scheduler.

The output fidelity of the AWG can also be improved using COTS filters from suppliers such as Mini-circuits®.

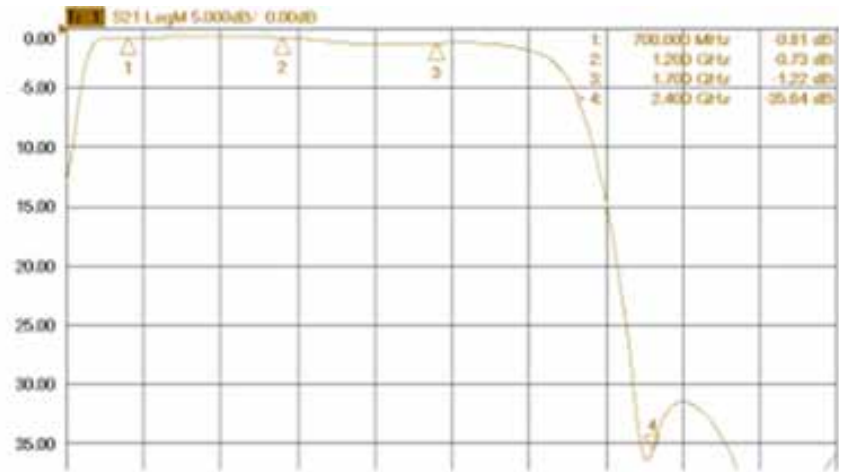





## Conclusions

For complex threat generation used in Radar system evaluation; a high sample-rate Arbitrary Waveform Generator like the Tektronix AWG70000 Series is a great source to consider. The AWG is a versatile instrument that can be programmed for simulation of microwave signaling as a threat source.

### Summary of System Specifications

Specifications	Direct to IF (ASG + AWG)	Direct to RF
Non-MOP frequency and pulse switching	< 1 $\mu$ s	< 1 $\mu$ s - 7 $\mu$ s (depending on AWG choice)
MOP Switching	< 1 $\mu$ s - 7 $\mu$ s (depending on AWG choice)	< 1 $\mu$ s - 7 $\mu$ s (depending on AWG choice)
Frequency Range	< 18 GHz	< 18 GHz
Power Flatness	< +/- 0.5 dB	< +/- 2 dB
IF Dynamic Range	> 60 dB	42 to 53 dBc
RF Dynamic Range (Attenuation Range)	90 dB (0.25 dB steps)	42 to 53 dBc

### Direct to Microwave

- Requires a (non-COTS) custom waveform scheduling system.
- Requires a (non -COTS) custom connectorized RFIU system with DDS, mixer, attenuators and a pulse modulator.
- Direct to microwave increases the likelihood of false targets with marginal SFDR in the 45 dBc to 50 dBc range.

### Direct to IF

- Simplified control model using Giga-tronics GT-ASGM18A.
- Wave front creation capability.
- Improved spectral purity with SFDR being better than 60 dBc.
- Built in DDS, pulse modulator and attenuators.
- Simple filtering using COTS filters from Mini-circuits® or other vendors.

**go-asg.gigatronics.com**

Phone: +1 925.328.4650

Email: asg-info@gigatronics.com

**www.tektronix.com**

Phone: +1 800.833.9200

Email: americas@enews.tektronix.com